

USER GUIDE

# CIRCULAR MUCK BIN

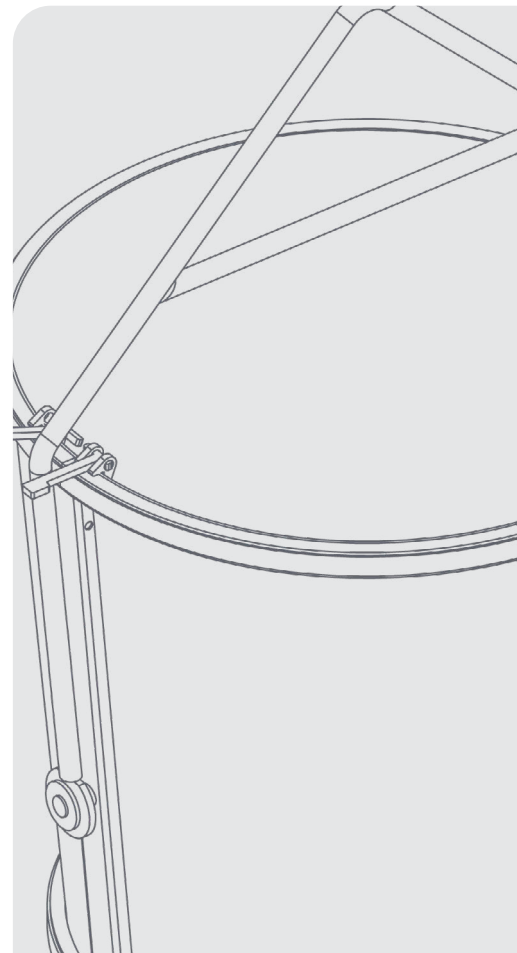

## DISCLAIMER

Do not attempt to handle or operate this equipment before you have received sufficient training. Before use, operatives must have carried out all checks featured on the Visual Inspection Sheet on page 11. It is imperative that you have read the General Safety Instructions on page 12 and sufficiently familiarised yourself with the Operational Procedures in this document.

Note that this item is compliant only to the standards specified in this User Guide and it is therefore the duty of the responsible person(s) to review and ensure compliance.

# CONTENTS

## PRODUCT INFORMATION

INTRODUCTION	05
SPECIFICATION	06
PARTS DIAGRAM	07

## OPERATIONAL PROCEDURES

IMPORTANT USAGE NOTES	08
USAGE INSTRUCTIONS	08

## MAINTENANCE & INSPECTION

MAINTENANCE REGIME	10
VISUAL INSPECTION SHEET	11

## GENERAL SAFETY INSTRUCTIONS

SAFETY INSTRUCTIONS	12
GENERAL NOTES	13

## LEGAL

TERMS AND CONDITIONS	14
EC DECLARATION OF CONFORMITY	18
STANDARDS AND REGULATIONS APPLICABLE	19

# INTRODUCTION

## OVERVIEW

The Conquip Circular Muck Bin is a traditional crane lift bin used for muck and waste removal. It is fitted with safety catches which are disengaged by hand, allowing the bin to self tip and empty automatically.

## KEY BENEFITS

- Bin empties automatically in response to the centre of gravity of the bale arm, removing the need for an operator to be in the dangerous discharge zone.
- Large capacity, providing easy method of transporting muck and waste across sites.

# SPECIFICATION

## THE RANGE

ITEM	PRODUCT CODE
Circular Muck Bin 100	CA109-00100
Circular Muck Bin 250	CA109-00250
Circular Muck Bin 500	CA109-00500
Circular Muck Bin 750	CA109-00750
Circular Muck Bin 1000	CA109-01000

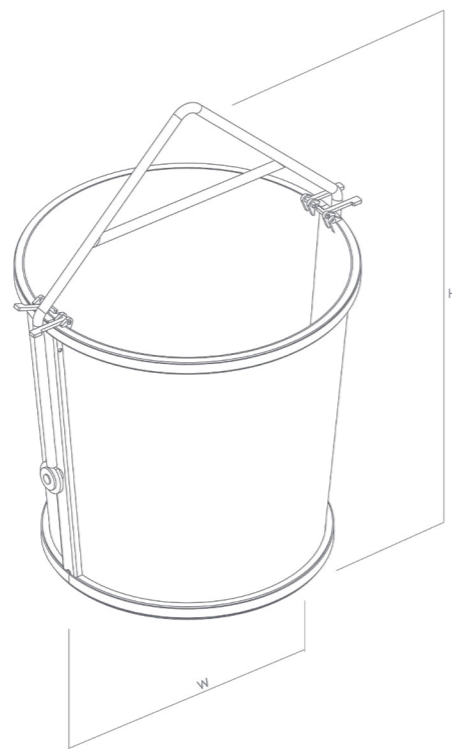

CODE	WIDTH (mm)	HEIGHT (mm)	HWB <sup>1</sup> (mm)	WEIGHT (kg)	WLL <sup>2</sup> (kg)	CAPACITY (litres)
CA109-00100	740	580	920	740	200	100
CA109-00250	940	770	1170	940	500	250
CA109-00500	1130	940	1460	1130	1000	500
CA109-00750	1300	910	1590	1300	1500	750
CA109-01000	1410	1150	1800	1410	2000	1000

<sup>1</sup> HWB = Height With Bale  
<sup>2</sup> Working Load Limit

# PARTS

## CIRCULAR MUCK BIN

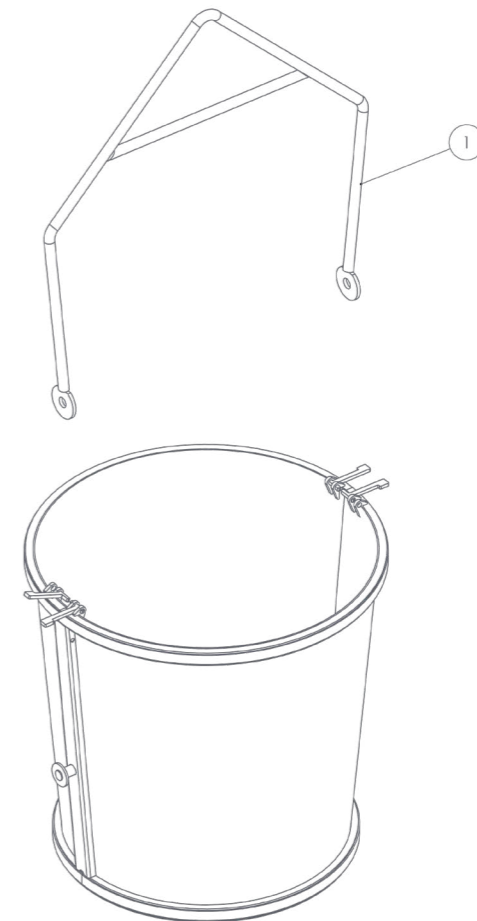

ITEM NUMBER	PART NUMBER	DESCRIPTION	QUANTITY
1	ZZ300000	Bale Arm for 100	1
	ZZ300024	Bale Arm for 250	
	ZZ300021	Bale Arm for 500	
	ZZ300013	Bale Arm for 750	
	ZZ300017	Bale Arm for 1000	
2	ZZ300018	Bale Arm Locking	4

NOTE: These parts are for this model, they may differ for previous versions. Please contact Conquip with any queries.

# OPERATIONAL PROCEDURES

## IMPORTANT USAGE NOTES

- Do not use the Circular Muck Bin for carrying toxic or dangerous materials or chemicals or light fires in or around the bin.
- Do not overfill the bin by volume or weight, the load should be evenly placed.
- At no point during the operation of this bin should personnel be within the discharge zone.
- Releasing of any safety catches must only be performed with the bin resting on the ground and positioned next to the discharge point.
- All of the lifting, tipping and manoeuvring must be carried out by a crane. Do not attempt to move the bin or the bale arm by hand.
- The Circular Muck Bin is for lifting and transporting waste and materials only. Do not use to raise or transport personnel.

## USAGE INSTRUCTIONS

- Attach the lifting apparatus' hook to the bin's bale arm lifting eye. Always ensure that the hook's gate is correctly closed and the lifting eye is seated correctly in the hook.
- If the bale arm is in the lowered position when attaching to the crane, raise the crane to bring the bale arm upright, turn all four safety catches outward and secure with the connected security locking pins.
- Carry out a test lift to familiarise yourself with the locking mechanism.
- Move the bin to the loading point and land the bin on firm level ground, which is able to bear the unit's weight and load.
- Make sure that the bale arm is in the raised position and that all safety catches are set outward.
- Fill the bin evenly, ensuring the load is no wider, longer or higher than the side walls.
- Once loaded and ready, clear all personnel from the area and raise the bin off the ground to check that the load is balanced and secure.
- The bin can now be carefully craned to the discharge area.
- Ensure that no personnel are in the discharge area and lower the bin to the ground.

- Turn one safety catch from each side of the bin inward – rear catch for forward tipping, front catch for backward tipping.
- Once the bin is ready to be discharged, clear all personnel from the area and raise the bin to allow it to tip and discharge.
- Having emptied the bin, lower it back to the ground into the resting position and lower the bale arm until back into the locking position.
- Turn the catches outward to secure the bale arm in the locked position.
- Raise the bin again and manoeuvre to the loading area.
- Once empty and lowered, disconnect the bin from the lifting apparatus.

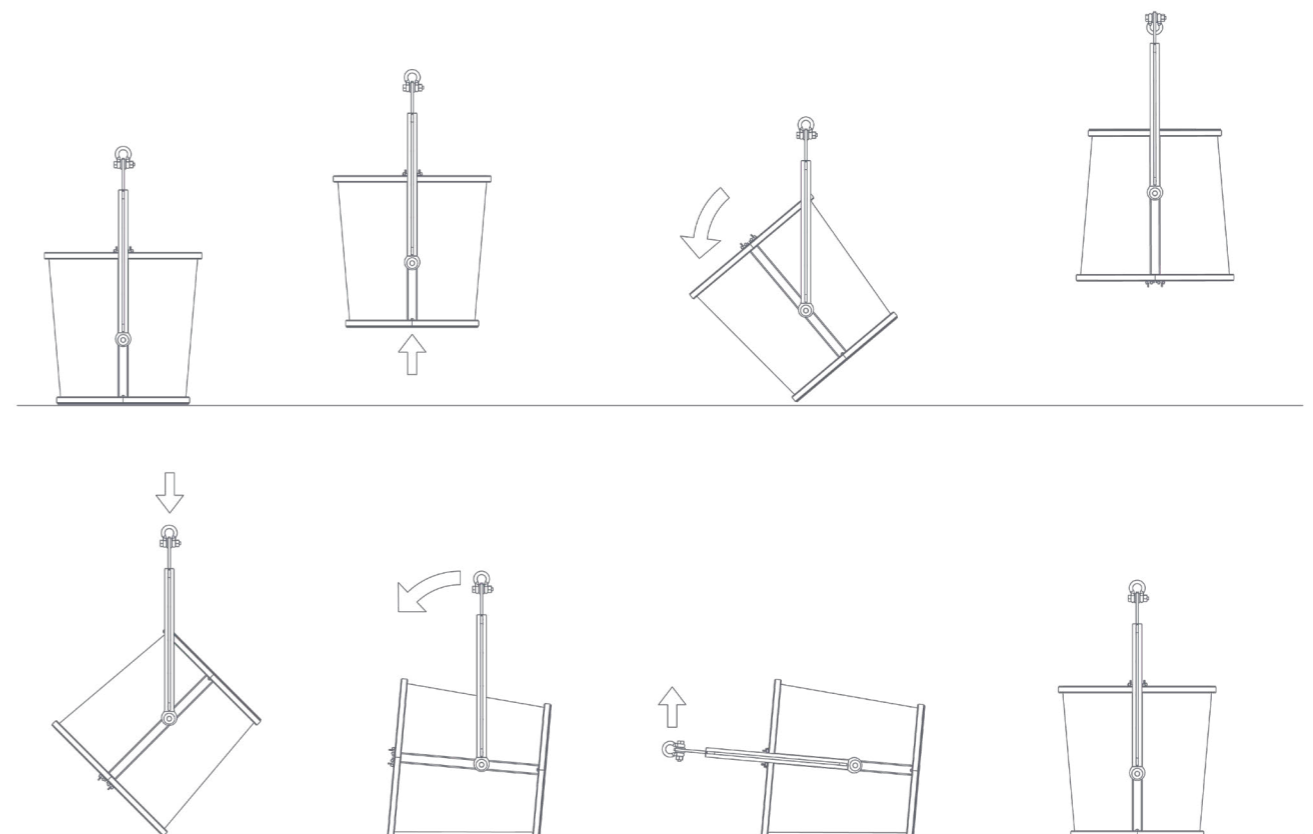

# MAINTENANCE & INSPECTION

## MAINTENANCE REGIME

- It is mandatory that the equipment is thoroughly examined regularly, by a qualified engineer, to ensure compliance with relevant regulations. Conquip recommend carrying out a thorough examination every six months.
- This equipment may incorporate various loose and detachable items including, but not limited to pins, bolt assemblies and adaption plates. Refer to the separate requirements for the safe use of those items.
- When not being used, store the unit in a clean, upright condition and in a safe place where it will be protected from thieves and unauthorised users.
- This equipment must be inspected by the responsible person before each use and then regularly, as determined by your risk assessment or working practice. If you have any concerns about the equipment's condition or suitability, do not use it.

## VISUAL INSPECTION CHECKLIST

INSPECTION ITEMS	RESULTS		COMMENTS
	SATISFACTORY	UNSATISFACTORY	
Serial Number			CQ.....
Product Code			
Working Load Limit (kg)			
Conforms to user guide specification			
Lift point bent or worn			
Bale arm bent			
Bale arm safety catches damaged			
Lift pins worn / damaged			
General visual inspection of the body			
SIGNATURE			
Name	Position	Qualification	Signature & Date

# GENERAL SAFETY INSTRUCTIONS

The equipment should be properly operated and maintained to keep it in a safe, efficient operating condition. Be sure that all fixings and components are free of mud or other matter that might cause issues hazardous to the operator, serviceman, or other personnel or equipment. Report all malfunctions to those responsible for maintenance, and do not operate the equipment until corrected. Normal service or maintenance performed as required can prevent unexpected and unnecessary downtime.

This operations manual describes general inspections, servicing and operation with the normal safety precautions required for normal servicing and operating conditions. It is not a guide, however, for abnormal conditions or situations, and therefore, servicemen and operators must be safety conscious and alert to recognise potential servicing or operating safety hazards at all times, and take necessary precautions to assure safe servicing and operation of the equipment.



**M002**  
Refer to instructions manual



**M004**  
Wear eye protection



**M008**  
Wear safety footwear



**M009**  
Wear protective gloves



**M010**  
Wear protective clothing



**M014**  
Wear head protection



**M015**  
Wear high-visibility clothing

## GENERAL NOTES

- Read this operations manual and learn the operating characteristics and limitations of the equipment. Know what operating clearances the machine requires.
- Read and understand all the safety signs prior to operation.
- If the safety signs are obstructed by dirt or debris, clean them using mild soap and water prior to operation.
- If the safety signs are damaged or illegible, replace them immediately, prior to operation.
- Be aware of operating hazards that weather changes can create on the job. Know proper procedures to follow when a severe rain or electrical storm strikes.
- Never attempt to operate or work on machinery when not feeling physically fit.
- Never wear loose clothing, rings, watches, heavy gloves etc., that might catch and result in injury.
- Know what safety equipment is required and use it. Such equipment may be: hard hat, safety glasses, reflector type vests, protective gloves and safety footwear.

# TERMS & CONDITIONS

## CONQUIP ENGINEERING GROUP STANDARD PRODUCT WARRANTY

### 01. COMMENCEMENT

1.1 This Warranty shall commence on the Commencement Date and shall continue until the earlier of:

- (a) the Expiry Date; or
- (b) the date on which it may be voided in accordance with clause 4.1(b)

when it shall terminate automatically without notice.

### 02. DUTY OF GOOD FAITH

2.1 The Purchaser shall in the exercise of its rights under this Warranty and in the compliance with its obligations under this Warranty be subject to and shall in all respects owe and comply with a duty of good faith to the Warrantor.

### 03. NATURE AND EXTENT OF COVER

3.1 Subject to clause 3.2 the Warrantor agrees and undertakes to the Purchaser that it shall be liable to the Purchaser under and in accordance with the terms of this Warranty in the event that:

- (a) prior to the Expiry Date the Purchaser shall notify a Warranty Claim to the Warrantor; and
- (b) the Equipment or any relevant part of the Equipment shall have become unusable as the result of defective material or defective workmanship prior to the Expiry Date.

3.2 The Warrantor's obligation under clause 3.1 shall be expressly subject to the provisions of clauses 4, 5 and 6 and conditional upon the Purchaser's compliance in full with the provisions of clause 7.

### 04. RESTRICTIONS

4.1 The following restrictions apply to this Warranty:

(a) This Warranty is personal to the Purchaser and neither the legal benefit nor legal burden of this warranty may be assigned or novated or otherwise transferred by the Purchaser to any other party. Any purported assignment, novation or transfer shall not be binding upon the Warrantor.

(b) This Warranty shall be void in the event that the Purchaser:

(i) cannot provide authentic and original documentary evidence that the Purchaser has during the period between the Commencement Date and the Expiry Date complied with the Maintenance and Servicing Requirements; and/or

(ii) has, during the period between the Commencement Date and the Expiry Date, exceeded the Purchaser's Usage Cycle Parameters; and/or

(iii) has, during the period between the Commencement Date and the Expiry Date, exceeded the Purchaser's Use Parameters; and/or

(iv) has carried out, or procured the carrying out by any third party of, any repair to the Equipment or any part of the Equipment which is not an Authorised Repair; and/or

(v) has operated the Equipment after having replaced any part of the Equipment with a part which has not been supplied and fitted by the Warrantor; and/or

(vi) has modified the Equipment in any way prior to use.

### 05. EXCLUSIONS

5.1 The following are excluded from the scope of this Warranty:

(a) Loss of and/ or damage to the Equipment or any part of it resulting from any collision between the Equipment and any other fixed or stationary or mobile object whatsoever, irrespective of whether that collision was or was not caused by the Purchaser; and/or

(b) Loss of and/or damage to any personal property and/or possessions or other equipment not forming part of the Equipment but which is present in or about the Equipment; and/or

(c) loss and/or damage which is covered by any other insurance policy taken out and maintained by the Purchaser or in respect of which the Purchaser has a contractual obligation to do so; and/or

(d) loss and/or damage to the equipment which is consistent with the use by the Purchaser of the Equipment:

(i) in compliance with the Maintenance and Servicing Requirements; and

(ii) in compliance with the Usage Cycle Parameters; and

(iii) in compliance with the Use Parameters; and

(iv) having only carried out Authorised Repairs to the Equipment; and

(v) having all and any replacement parts fitted by the Warrantor; and

(vi) in unmodified form.



## 06. LIMITATION OF LIABILITY

6.1 The Warrantor's liability to the Purchaser shall be limited as follows:

- (a) The Warrantor shall not in any circumstances be liable to the Purchaser for indirect and/or consequential and/or economic loss suffered and/or incurred as the case may be by the Purchaser; and
- (b) The Warrantor shall only be liable to the Purchaser for the reasonable and proper costs reasonably and properly incurred by the Purchaser directly in connection with the repair and/or replacement (at the Warrantor's absolute discretion) of the Equipment or any part of the Equipment; and
- (c) The Warrantor's liability to the Purchaser shall notwithstanding any other provision of this Warranty, not in any circumstances exceed the Purchase Price of the Equipment.

## 07. WARRANTY CLAIMS

7.1 The Purchaser shall in respect of any claim against the Warrantor under this Warranty and within 24 hours of the occurrence of the subject matter of the Warranty Claim:

- (a) Complete in full and submit to the Warrantor a Warranty Claim in the form annexed to Schedule 4;
- (b) Provide date stamped or date identifiable photographs evidencing the claim; and
- (c) Make the Equipment or the relevant part of the Equipment available to the Warrantor for inspection within 48 hours of notification of the relevant Warranty Claim.

## 08. ENTIRE AGREEMENT

8.1 This Warranty constitutes the entire agreement between the parties and supersedes and extinguishes all previous promises, assurances, warranties, representations and understandings between them, whether written or oral, relating to its subject matter.

8.2 Each party agrees that it shall have no remedies in respect of any statement, representation, assurance or warranty (whether made innocently or negligently) that is not set out in this Warranty. Each party agrees that it shall have no claim for innocent or negligent misrepresentation or negligent misstatement based on any statement in this Warranty.

No variation of this Warranty shall be effective unless it is in writing and signed by the parties (or their authorised representatives).

## 09. WAIVER

No failure or delay by a party to exercise any right or remedy provided under this Warranty or by law shall constitute a waiver of that or any other right or remedy, nor shall it prevent or restrict the further exercise of that or any other right or remedy. No single or partial exercise of such right or remedy shall prevent or restrict the further exercise of that or any other right or remedy.

## 10. SEVERANCE

10.1 If any provision or part-provision of this Warranty is or becomes invalid, illegal or unenforceable, it shall be deemed deleted, but that shall not affect the validity and enforceability of the rest of this Warranty.

10.2 If any provision or part-provision of this Warranty is deemed deleted under clause 10.1 the parties shall negotiate in good faith to agree a replacement provision that, to the greatest extent possible, achieves the intended commercial result of the original provision.

## 11. THIRD PARTY RIGHTS

11.1 This Warranty does not give rise to any rights under the Contracts (Rights of Third Parties) Act 1999 to enforce any term of this Warranty.

## 12. GOVERNING LAW

12.1 This Warranty and any dispute or claim (including non-contractual disputes or claims) arising out of or in connection with it or its subject matter or formation shall be governed by and construed in accordance with the law of England and Wales.

## 13. JURISDICTION

13.1 Each party irrevocably agrees that the courts of England and Wales shall have exclusive jurisdiction to settle any dispute or claim (including non-contractual disputes or claims) arising out of or in connection with this Warranty or its subject matter or formation.

# EC DECLARATION OF CONFORMITY

## IN ACCORDANCE WITH EN ISO 17050-1:2004

Declaration: As defined by the Machinery Directive 2006/42/EC and subsequent amendments

We, CONQUIP ENGINEERING GROUP, herewith declare that the following indicated equipment meets the fundamental health and safety requirements concerning the EU guideline(s), due to their design and manufacture.

This declaration will be rendered null and void if the machine is changed without our approval.

**SIGNED:**



**DATED: 2024**

Garry Critchley, Chief Executive Officer

PRODUCT CODES	GENERAL DESCRIPTION / DESIGNATION	WORKING LOAD LIMIT
CA109-00100	Circular Muck Bin 100	200kg
CA109-00250	Circular Muck Bin 250	500kg
CA109-00500	Circular Muck Bin 500	1000kg
CA109-00750	Circular Muck Bin 750	1500kg
CA109-01000	Circular Muck Bin 1000	2000kg

ITEM	CODE	DESCRIPTION
<b>EC DIRECTIVE/REGULATION</b>	2006/42/EC	Directive 2006/42/EC- new machinery directive
<b>HARMONISED STANDARDS</b>	BS EN ISO 12100:2010	Safety of machinery General principles for design Risk assessment and risk reduction
<b>OTHER REGULATIONS</b>	LOLER 1998	Lifting Operations and Lifting Equipment Regulations 1998 (LOLER)
	PUWER 1998	Provision and Use of Work Equipment Regulations 1998 (PUWER)

TALKING TO US IS EASY  
**WE'RE HERE TO HELP**

Call us on (02) 8844 4590  
Email us at [sales@conquipgroup.com.au](mailto:sales@conquipgroup.com.au)  
[www.cqegroup.com/au](http://www.cqegroup.com/au)

