



User Guide

Lifting Equipment Storage

Container



Product Information

Overview

A container for storing lifting chains and accessories.

The Lifting Equipment Storage Container is a robust, steel container designed to store lifting equipment safely and securely. Available in two sizes, these containers come complete with internal shelving for accessories and racking for all types and sizes of lifting chains.

Each size can be supplied with internal lighting, mains power and an external power socket, if required. Lifting points and fork pockets allow for easy manoeuvre around site minimising downtime.

Key Benefits

- Available in 10' and 20' sizes.
- Can be supplied with or without lighting and electrics.
- Internal racking for lifting chains and shelving for lifting accessories.
- Safe and secure storage prevents loss or theft of equipment and protects it against weather deterioration.
- Easily manoeuvred around site via crane or forklift.

Product Information Specification

Item	Product Code(s)
Lifting Equipment Storage Container	ST136-16000, ST136AA-16000

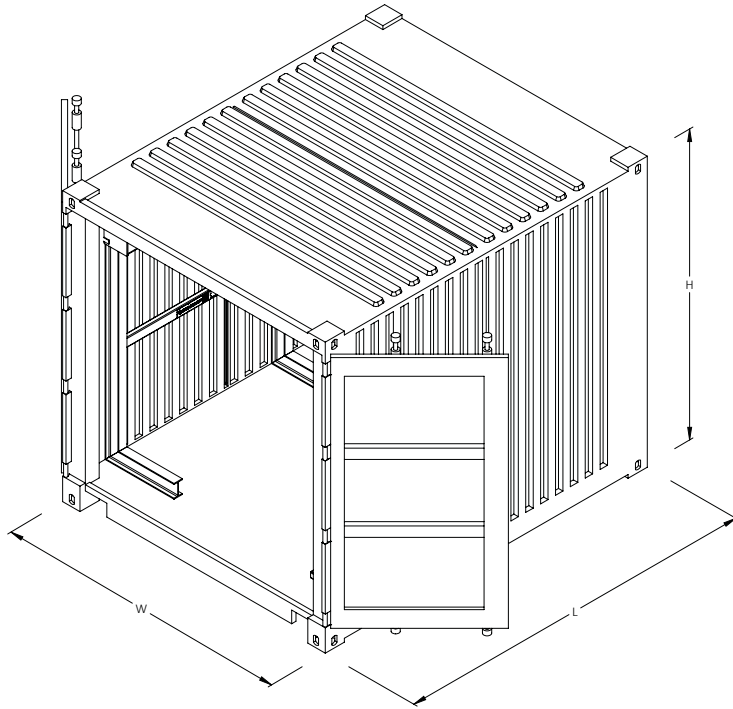

Product Code	Height	Width	Length	Weight
ST136-16000, ST136AA-16000	2600mm	2440mm	3000mm	1695kg

¹Working Load Limit

Product Code	Container WLL ¹	Shelving WLL ¹	Shackle Rack WLL ¹	Chain Rack WLL ¹
ST136-16000, ST136AA-16000	9,605kg	900kg (300kg per shelf)	750kg (50kg per hook)	1500kg (250kg per hook)

Product Information Specification

Item	Product Code(s)
Lifting Equipment Storage Container	ST136-33200, ST136AA-33200

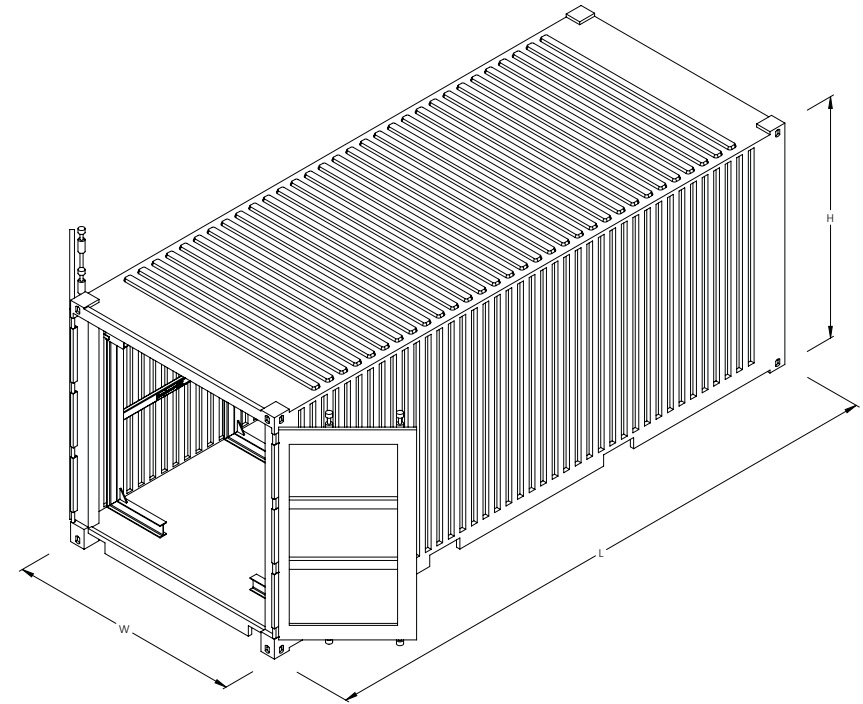

Product Code	Height	Width	Length	Weight
ST136-33200, ST136AA-33200	2600mm	2440mm	6058mm	2975kg

¹Working Load Limit

Product Code	Container WLL ¹	Shelving WLL ¹	Shackle Rack WLL ¹	Large Chain Rack WLL ¹	Small Chain Rack WLL ¹
ST136-33200, ST136AA-33200	27,520kg	900kg (300kg per shelf)	1650kg (50kg per hook)	4000kg (250kg per hook)	1250kg (250kg per hook)

Original Working Instructions

Safety Instructions

Basic Safety

A site-specific Risk Assessment, and lift plan where applicable, must be completed by the responsible person before using this equipment to control risks, produce a safe system of work and ensure safety for you, your colleagues and others. Your risk assessment will determine the correct Personal Protective Equipment (PPE) for the task you are doing. You must use it. Conquip recommends that you should wear:

- Suitable clothing
- Gloves
- Hard hat
- Protective footwear (steel toecaps)
- Safety glasses



Important Safety Notes

- Read these instructions before using this equipment. If there is anything you do not understand or if you have any concerns do not use this equipment. Contact your supervisor or Conquip Engineering Group for advice.
- You must check that you have considered all the safety requirements for the task you are doing and that this equipment is suitable.
- You must protect bystanders and the general public by preventing access to the working area.
- Do not use this equipment if you are tired, unwell or under the influence of alcohol or drugs. If you are taking any medicine or undergoing treatment you should inform your supervisor.

Usage & Transportation

- Never unevenly load this equipment.
- The weight of the equipment, together with its attachments, must be added to the weight of the load when calculating the total load that will be imposed on the lifting apparatus / operating machine.
- This equipment must be used in conjunction with the load ratings of the lifting apparatus / operating machine. (Refer to the manufacturers' load ratings and original working instructions).
- Make sure you know how to use this equipment and understand all aspects of its operation in case of emergency.
- This equipment weighs more than 25kg. Do not lift or manhandle without machine assistance.
- Do not operate this equipment near overhead power lines.
- Take care in confined spaces, near ceilings or similar hazards. This equipment was designed for vertical lifting. Do not drag, or swing.
- Before operating this equipment, check that you have enough space for you to work safely and make sure that the working area is clear of hazards, obstructions and personnel.
- Before lowering equipment make sure that the landing zone is clear and capable of accepting the size and weight of the load.
- Crush Risk. Keep hands and feet clear of the equipment at all times to avoid injury.
- Do not exceed the maximum Working Load Limit (WLL) shown on the serial plate. Ensure that the WLL on the individual lift points is not exceeded.
- Before lifting, check that the load is secured, balanced and stable. Allow space for the equipment to move if the load shifts.
- Manoeuvre loaded or raised equipment carefully. Travel and turn slowly to avoid unit becoming unstable.

Personnel

- All personnel must wear relevant personal protective equipment.
- Do not wear loose clothing or jewellery and tie back long hair to avoid becoming tangled or trapped in this equipment. You must make everyone in the work area aware of what you are doing.
- All personnel involved in the lifting operation must be competent to do so and must have been briefed in conjunction with this User Guide available from Conquip Engineering Group, the manufacturer.

Equipment Maintenance & Cleaning

- It is mandatory that the equipment is thoroughly examined regularly, by a qualified engineer, to ensure compliance with relevant regulation/s. (Conquip recommend to carry out thorough examination every six months).
- This product may incorporate various loose and detachable items of lifting gear. Refer to the separate requirements for the safe use of those items.
- When not being used, store the unit in a clean, upright condition and in a safe place where it will be protected from thieves and unauthorised users.
- This equipment must be inspected by the responsible person before each use and then regularly, as determined by your risk assessment or working practice. If you have any concerns about condition or suitability do not use.

Disclaimer

Warranty

The products supplied by Conquip Engineering Group are all guaranteed by a 12 month warranty.

Apart from where exceptions apply, Conquip Engineering Group promises to repair or replace any fault which the Company considers to be due to defective material or workmanship within 12 months of the date of sale, at no additional cost.

- Faults arising from unauthorised alterations (see modifications section below for full details).
- Damage caused by abuse, neglect, misuse or falling.
- Damage caused because of failure to follow transportation, storage, loading, cleaning or operating instructions.
- Replacement or repair of components due to fair wear and tear.
- Any consequential damage or wear arising from the use or fitting of additional or non-standard parts.

Modifications

If any third-party modifications or alterations, involving drilling, welding, cutting or distortion of materials in any form, are to be carried out on the product, Conquip Engineering Group must provide full written approval prior to the work being carried out.

Alterations, modifications, additions or repairs must be carried out by Conquip Engineering Group's recognised distributors, if they are not carrying out the work themselves.

Conquip Engineering Group operate a continuous improvement policy and therefore reserve the right to alter technical specifications and user guide details at any point without notice.

Conquip Engineering Group will not cover or reimburse any transportation and/or shipment costs to and from their premises or their recognised agents, or any material and/or labour costs for repair, replacement or assessment against a warranty claim.

Conquip Engineering Group and/or their directors, employees, insurers or recognised agents will not be held liable for consequential damages, losses or expenses relating to the inability to use the product correctly for its purpose.

EC Declaration of Conformity

In accordance with EN ISO 17050-1:2004

Declaration: As defined by the Machinery Directive 2006/42/EC and subsequent amendments

We, CONQUIP ENGINEERING GROUP, herewith declare that the following indicated equipment meets the fundamental health and safety requirements concerning the EU guide line(s), due to their design and manufacture.

This declaration will be rendered null and void if the machine is changed without our approval.

Signed:



Dated: 2021

Garry Critchley, Managing Director

Product Code(s):	ST136-16000, ST136AA-16000, ST136-33200, ST136AA-33200
EC Directive/Regulation:	2006/42/EC, Lifting Operations and Lifting Equipment Regulations 1998 Provision and Use of Work Equipment Regulations 1998
Harmonised Standards:	BS EN ISO 12100:2010
General Description/Designation:	Lifting Equipment Storage Container – ST136-16000, ST136AA-16000, ST136-33200, ST136AA-33200
WLL:	ST136-16000, ST136AA-16000 = 9,605kg ST136-33200, ST136AA-33200 = 27,520kg

Important Notes

- This User Guide is for this Conquip product only.
- Any movements of the product must be thoroughly planned before the work commences to identify potential hazards and assess risk.
- All personnel involved in lifting and transportation of this product must have read this User Guide and must be properly briefed.
- You must be competent, alert and medically fit when using this equipment. If you have a medical condition, a mental or physical disability, you must seek advice from a medical professional before using this equipment.

Talking to us is easy

We're here to help

Call us on +44 (0) 333 3000 3470

Email us at sales@cqegroup.com

www.cqegroup.com

Conquip Engineering Group

Waterbrook Estate, Alton, Hampshire, GU34 2UD