



User Guide

Manhole Box



Product Information

Overview

The Conquip Manhole Box is a simple to assemble, two sided trench lining support system designed to be installed by an excavator using the 'dig and push' technique, or by simply carrying out the excavation and then lowering each box into place.

The Manhole Boxes are available in a range of sizes: 2.5m, 3.5m and 4.0m external length. Extensions available for trench depths of up to 5.18 metres and widths of up to 4 metres.

Manufactured in the UK from quality British and EU steel.

Conquip also supply a full range of suitable lifting and extraction chains, edge protection and trench access accessories.

Product Information Specification

Item	Product Code
Base Box 2500	TL103-00011
Base Box 3500	TL103-00007
Base Box 4000	TL103-00009

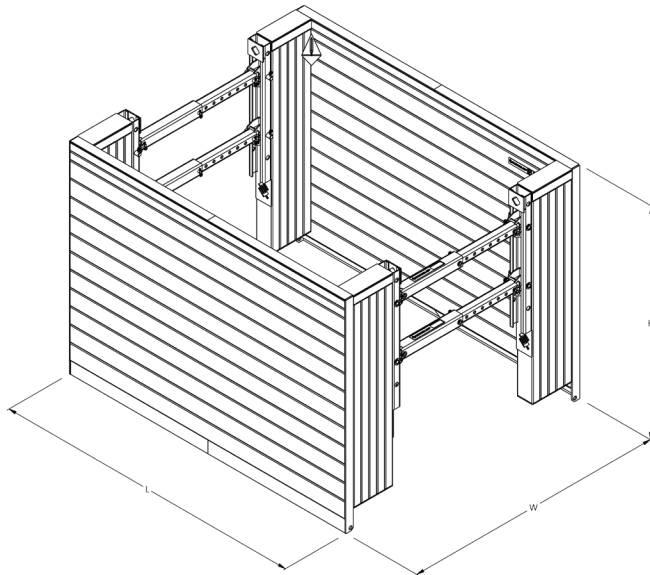

¹Weight will be equal to or less than the weight stated depending on your strut configuration.

Product Code	Height	External Length	Internal Length
TL103-00011	2560mm	2500mm	2180mm
TL103-00007	2560mm	3500mm	3180mm
TL103-00009	2560mm	4000mm	3680mm

Product Code	Working Width (Min - Max)	Maximum Weight ¹	Limit State Design Load
TL103-00011	2070-3470mm	2,766kg	80.96 kN/m ²
TL103-00007	2070-3470mm	3,266kg	57.83 kN/m ²
TL103-00009	2070-3470mm	3,516kg	45.43 kN/m ²

Product Information Specification

Item	Product Code
Extension Box 2500	TL103-00012
Extension Box 3500	TL103-00008
Extension Box 4000	TL103-00010

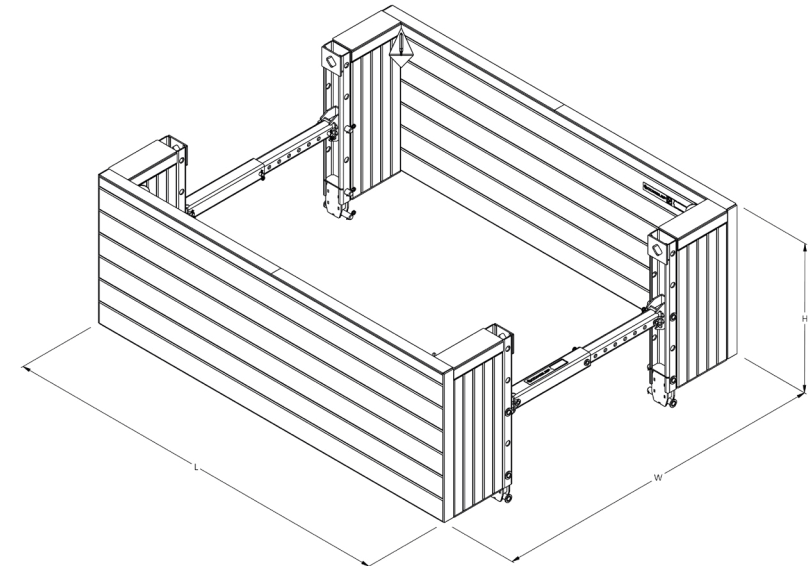

¹Weight will be equal to or less than the weight stated depending on your strut configuration.

Product Code	Height	External Length	Internal Length
TL103-00012	1310mm	2500mm	2180mm
TL103-00008	1310mm	3500mm	3180mm
TL103-00010	1310mm	4000mm	3680mm

Product Code	Working Width (Min - Max)	Maximum Weight ¹	Limit State Design Load
TL103-00012	2070-3470mm	1,592kg	80.96 kN/m ²
TL103-00008	2070-3470mm	1,872kg	57.83 kN/m ²
TL103-00010	2070-3470mm	1,972kg	45.43 kN/m ²

Product Information
Parts Diagram

Manhole Base Box

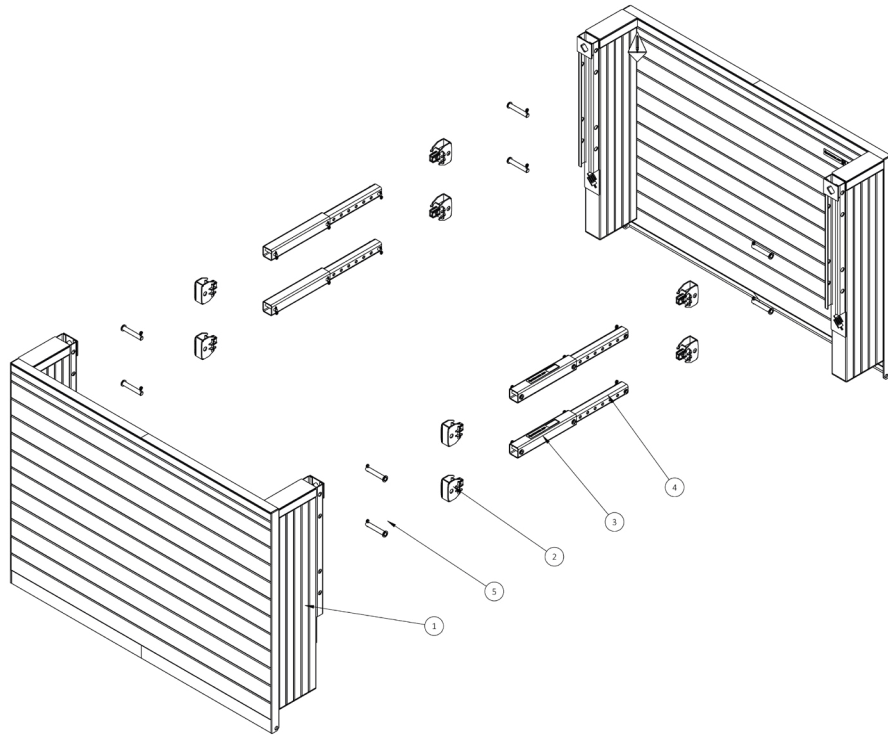

NOTE: These parts are for this model, they may differ for previous versions. Please contact Conquip with any queries.

Item Number	Description	Quantity
1	Manhole Box Base Panel	2
2	Shoring Rocker Assembly	8
3	Incremental Strut Section	4
4	Incremental Strut Section	4
5	40mm Pin Assembly	8

Product Information
Parts Diagram

Manhole Extension Box

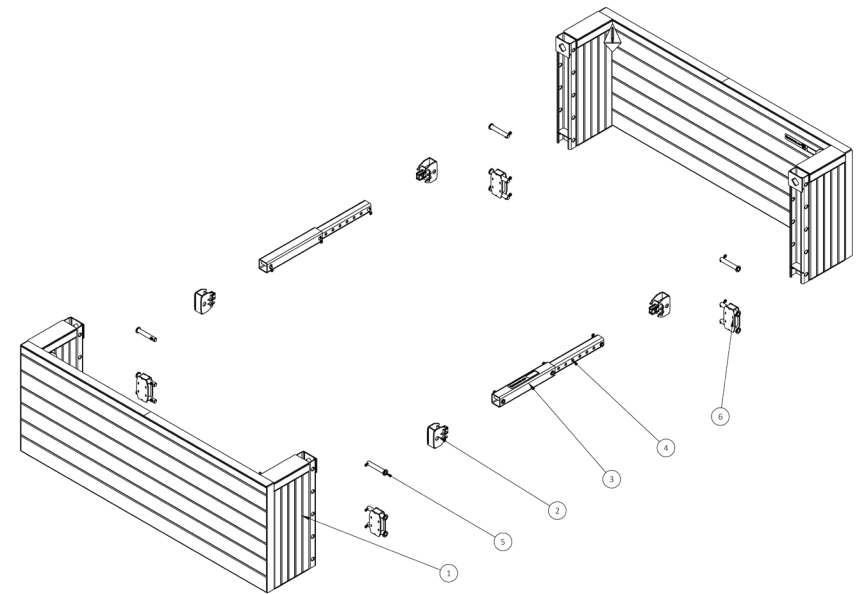

NOTE: These parts are for this model, they may differ for previous versions. Please contact Conquip with any queries.

Item Number	Description	Quantity
1	Manhole Box Extension Panel	2
2	Shoring Rocker Assembly	4
3	Incremental Strut Section	2
4	Incremental Strut Section	2
5	40mm Pin Assembly	12
6	Connection Brackets	4

Original Working Instructions

Usage Instructions

Important Assembly Notes

- Top extension boxes are to be assembled in the same way but only two struts should be fitted. Extension boxes are secured to the base boxes using connector brackets and pins.
- Keep hands clear of naked surfaces.

Assembly Instructions

1. Using a certified lifting sling connected to the four corner lifting points, lift the panel onto some bearers and using the pins provided connect the rocker assembly to the panel. (Fig 1.1)
2. Place all four struts onto the rockers protruding from the panel facing upwards and secure them using the pins and R-clips supplied. (Fig 1.2)
3. Then connect the four remaining rocker assemblies to the struts using the 40mm pins and R-clips supplied.
4. Connect the sling to the lifting points of the panel facing downwards and lift it into position above the struts.
5. Lower the plate carefully, guiding the runners onto the four upright strut assemblies.
6. Secure the struts to the panel with the remaining four pins and R-clips. (Fig 1.3)
7. Disconnect the lifting sling connection points from the two lower lifting points and lift the box to the upright working position.
8. Connect the two free legs of the lifting sling to the upper lifting points of the other panel before lifting the box into the trench.

Fig 1.1

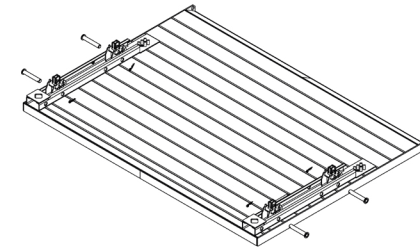

Fig 1.2

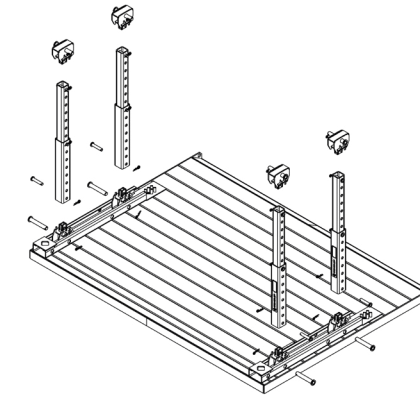
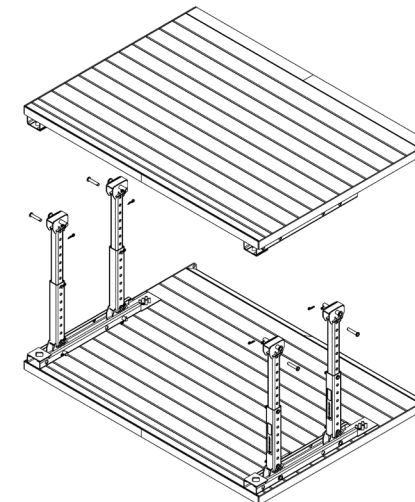

Fig 1.3



Original Working Instructions

Usage Instructions

Connecting Extensions Boxes

1. The base box and extension box are connected via a connector bracket.
2. The connector bracket will fit within the panel soldier of the base box and is secured using a 40mm pin and R-clip.
3. The extension box is then placed on top of the base box. The protruding connector bracket must lock into the top of the panel soldier of the extension box.
4. Once in place, insert a 40mm \varnothing pin through the panel soldier and connector bracket. Secure with an R-clip.

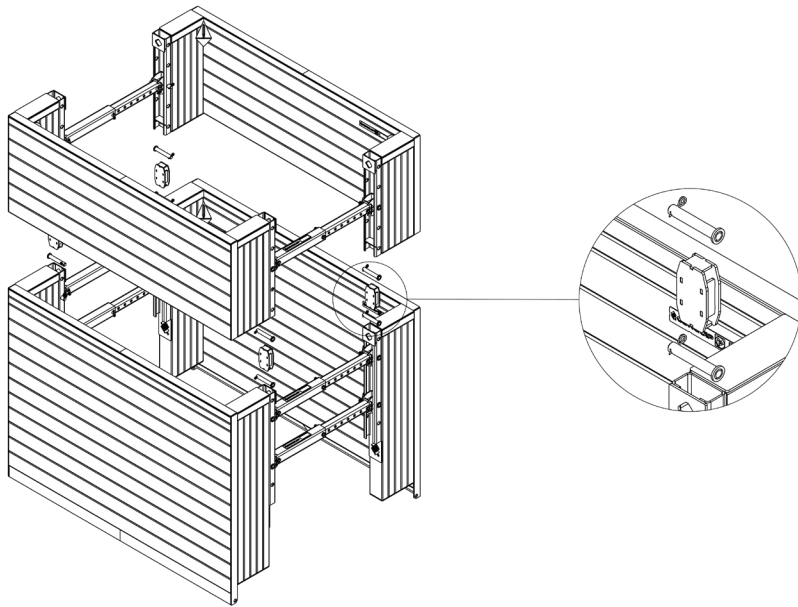

Original Working Instructions

Usage Instructions

Important Installation Notes

- All personnel involved in installation must wear relevant personal protective equipment.
- Never enter an unsupported excavation.
- Stage 6 should be carried out when the top of the base is approximately 200mm above ground level.
- It is mandatory to use edge protection when

Usage Instructions

1. Excavate the ground to approximately 1m or deeper, as ground conditions permit.
2. Lower the box into the trench using a certified 4 leg chain sling of the correct volume.
3. The excavator operator then digs progressively between the two faces of the box panels.
4. The operator then uses the back of the bucket of the excavator to push down on the 4 corners of the box in turn.
5. Repeat steps 3 and 4 until the desired depth is reached.
6. When attaching a top extension, these should be attached to the Base Box at each corner, using connectors supplied. Each connector is secured using a pair of pins and R-clips.

Extraction

1. Simply reverse the installation process, start by backfilling the trench.
2. Progressively pull the box upwards using a certified 4 leg lifting chain sling.
3. If extension boxes have been used, these should be disconnected as the joint becomes clear of the ground and then lifted clear before reconnecting the sling to the Base Box and continuing the extraction.

Original Working Instructions

Safety Instructions

Basic Safety

A site-specific Risk Assessment, and lift plan where applicable, must be completed by the responsible person before using this equipment to control risks, produce a safe system of work and ensure safety for you, your colleagues and others. Your risk assessment will determine the correct Personal Protective Equipment (PPE) for the task you are doing. You must use it. Conquip recommends that you should wear:

- Suitable clothing
- Gloves
- Hard hat
- Protective footwear (steel toecaps)
- Safety glasses



Important Safety Notes

- Read these instructions before using this equipment. If there is anything you do not understand or if you have any concerns do not use this equipment. Contact your supervisor or Conquip Engineering Group for advice.
- You must check that you have considered all the safety requirements for the task you are doing and that this equipment is suitable.
- You must protect bystanders and the general public by preventing access to the working area.
- Do not use this equipment if you are tired, unwell or under the influence of alcohol or drugs. If you are taking any medicine or undergoing treatment you should inform your supervisor.

Usage & Transportation

- Never unevenly load this equipment.
- The weight of the equipment, together with its attachments, must be added to the weight of the load when calculating the total load that will be imposed on the lifting apparatus / operating machine.
- This equipment must be used in conjunction with the load ratings of the lifting apparatus / operating machine. (Refer to the manufacturers' load ratings and original working instructions).
- Make sure you know how to use this equipment and understand all aspects of its operation in case of emergency.
- This equipment weighs more than 25kg. Do not lift or manhandle without machine assistance.
- Do not operate this equipment near overhead power lines.
- Take care in confined spaces, near ceilings or similar hazards. This equipment was designed for vertical lifting. Do not drag, or swing.
- Before operating this equipment, check that you have enough space for you to work safely and make sure that the working area is clear of hazards, obstructions and personnel.
- Before lowering equipment make sure that the landing zone is clear and capable of accepting the size and weight of the load.
- Crush Risk. Keep hands and feet clear of the equipment at all times to avoid injury.
- Do not exceed the maximum Working Load Limit (WLL) shown on the serial plate. Ensure that the WLL on the individual lift points is not exceeded.

Personnel

- All personnel must wear relevant personal protective equipment.
- Do not wear loose clothing or jewellery and tie back long hair to avoid becoming tangled or trapped in this equipment. You must make everyone in the work area aware of what you are doing.
- All personnel involved in the lifting operation must be competent to do so and must have been briefed in conjunction with this User Guide available from Conquip Engineering Group, the manufacturer.

Equipment Maintenance & Cleaning

- It is mandatory that the equipment is thoroughly examined regularly, by a qualified engineer, to ensure compliance with relevant regulation/s. (Conquip recommend to carry out thorough examination every six months).
- This product may incorporate various loose and detachable items of lifting gear. Refer to the separate requirements for the safe use of those items.
- When not being used, store the unit in a clean, upright condition and in a safe place where it will be protected from thieves and unauthorised users.
- This equipment must be inspected by the responsible person before each use and then regularly, as determined by your risk assessment or working practice. If you have any concerns about condition or suitability do not use.

Disclaimer

Warranty

The products supplied by Conquip Engineering Group are all guaranteed by a 12 month warranty.

Apart from where exceptions apply, Conquip Engineering Group promises to repair or replace any fault which the Company considers to be due to defective material or workmanship within 12 months of the date of sale, at no additional cost.

- Faults arising from unauthorised alterations (see modifications section below for full details).
- Damage caused by abuse, neglect, misuse or falling.
- Damage caused because of failure to follow transportation, storage, loading, cleaning or operating instructions.
- Replacement or repair of components due to fair wear and tear.
- Any consequential damage or wear arising from the use or fitting of additional or non-standard parts.

Modifications

If any third-party modifications or alterations, involving drilling, welding, cutting or distortion of materials in any form, are to be carried out on the product, Conquip Engineering Group must provide full written approval prior to the work being carried out.

Alterations, modifications, additions or repairs must be carried out by Conquip Engineering Group's recognised distributors, if they are not carrying out the work themselves.

Conquip Engineering Group operate a continuous improvement policy and therefore reserve the right to alter technical specifications and user guide details at any point without notice.

Conquip Engineering Group will not cover or reimburse any transportation and/or shipment costs to and from their premises or their recognised agents, or any material and/or labour costs for repair, replacement or assessment against a warranty claim.

Conquip Engineering Group and/or their directors, employees, insurers or recognised agents will not be held liable for consequential damages, losses or expenses relating to the inability to use the product correctly for its purpose.

EC Declaration of Conformity

In accordance with EN ISO 17050-1:2004

Declaration: As defined by the Machinery Directive 2006/42/EC and subsequent amendments

We, CONQUIP ENGINEERING GROUP, herewith declare that the following indicated equipment meets the fundamental health and safety requirements concerning the EU guide line(s), due to their design and manufacture.

This declaration will be rendered null and void if the machine is changed without our approval.

Signed:



Dated: 2021

Garry Critchley, Managing Director

Product Code(s):

TL103-00011 / TL103-00007 / TL103-00009 / TL103-00012 / TL103-00008 / TL103-00010

EC Directive/ Regulation:

2006/42/EC,
Lifting Operations and Lifting Equipment Regulations 1998
Provision and Use of Work Equipment Regulations 1998

Harmonised Standards:

BS EN ISO 12100:2010 / BS EN 12811-2:2004 / BS EN 13331-1:2002

General Description/ Designation:

Manhole Box – TL103-00011 / TL103-00007 / TL103-00009 / TL103-00012 / TL103-00008 / TL103-00010

WLL:

TL103-00011 / TL103-00007 / TL103-00009 / TL103-00012 / TL103-00008 / TL103-00010 = N/A

Important Notes

- This User Guide is for this Conquip product only.
- Any movements of the product must be thoroughly planned before the work commences to identify potential hazards and assess risk.
- All personnel involved in lifting and transportation of this product must have read this User Guide and must be properly briefed.
- You must be competent, alert and medically fit when using this equipment. If you have a medical condition, a mental or physical disability, you must seek advice from a medical professional before using this equipment.

Talking to us is easy

We're here to help

Call us on 0333 300 3470

Email us at sales@cqegroup.com

www.cqegroup.com

Conquip Engineering Group

Waterbrook Estate, Alton, Hampshire, GU34 2UD